

Installation tools checklist

4mm and 6mm allen keys

Hammer drill - For concrete anchors you will require a carbide tip masonry drill 10mm W x 180mm L

For other substrates you will need alternative drill bits.

For fitting handrail, you require 4.5mm stainless steel drill bit and a 5mm thread tapping set. Please see page 13.

Torque wrench and socket set for 8mm bolts -You may need this to tighten your anchors on site.

Dual resin gun - If you purchase our resin you will require a dual resin gun. You can buy this on your order form.

Glass suction cups - This is optional but can help with the movement around site and during the installation itself.

Gloves and wrist guards - This is standard PPE for using and handling glass products safely.

Screwdriver - This is required if you are attaching a wall flange to a wall.

Scotch brite cleaning pads- This can be used to clean any marks of scuffs on the material that may happen during the installation.

Black marker pen - You will need this to mark where on the handrail to drill your fixing points.

Loctite 638 glue and Loctite SF7649 activator - You will need to buy this if fitting slotted handrail. The activator is only required in the event you wish to reduce the drying time for the Loctite 638 use.

Chop saw with stainless steel cutting blade - This is only required for a stainless-steel handrail as we always supply lengths slightly longer than required. This allows you to ensure you have an exact fit on site. It is impossible to drill and cut the handrail to length as there are glass tolerances to consider and this would provide no flexibility on site for your installation.

Semi frameless post with no handrail system - glass clamps

The post with no handrail system if protecting a fall over a height of 600mm requires toughened laminate glass with fixing holes drilled in the glass. As such, it is more expensive than both of the post with handrail systems. If the system is not protecting a fall of more than 600mm and is purely a windshield or partition, 10mm glass can be used and it is our most affordable solution. As such you will only use the security with the clamps if you have purchased toughened laminated glass.



During Your Install Process

Stainless steel is quite a soft metal so during your install process refrain from cutting and grinding work close to the components as this can inlay metal sparks/contaminates into your stainless steel which may affect its corrosion resistant qualities. All works should be carried out in an alternate area and cover the any component exposed areas as much as possible if cutting/grinding them

Base plate installation



We always recommend you mark and layout your post system prior to starting your installation. Once you have checked your posts are all in the correct locations from the drawings provided you can start to drill your anchor points.

It is a good idea to start one end and work along each run to its completion. The ground surface needs to be flat but metal shims can be used in the event there is some minor deviations. Once the posts are all in position you can then look to fit your handrail system followed by the glass into the clamps using your allen keys.

Post Features

- Slimline, elegant design with low maintenance and BS6180:2011 compliant
- External grade 316 stainless steel brushed aluminum 320 grit finish
- All our 48.3mm diameter posts are supplied with fitted welded base plates, base covers and clamps
- Vertical and horizontal mounting solutions
- Available with or without handrail
- Simple and easy to install

Fixing points

Base plate

We do on occasion use alternative base plates that are not shown.

If the footprint of your base plate is critical please advise your salesperson.

With all our posts the base plate comes with an attractive cover as shown in the picture opposite.

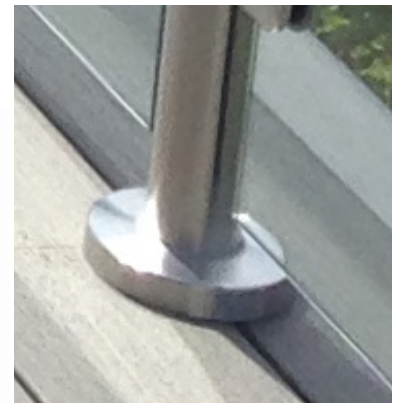

Base plate 1 100mm wide

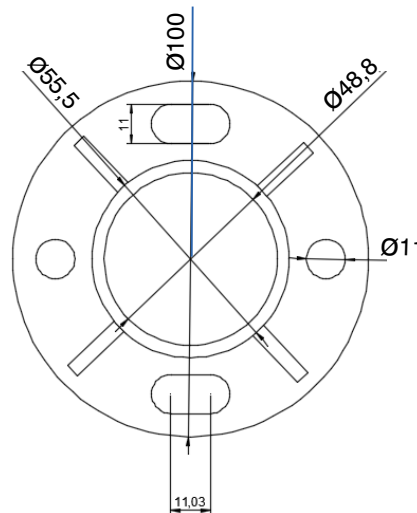
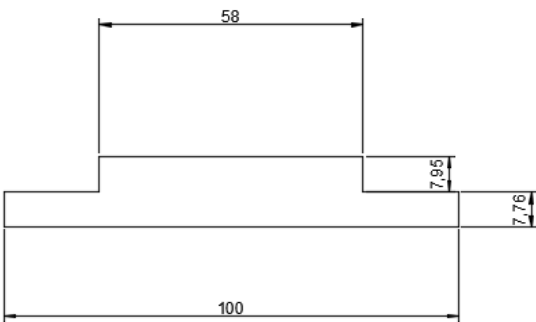

With covers on - 105mm

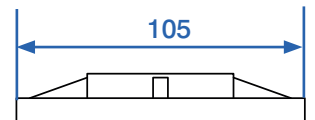

Base plate 2 120mm wide

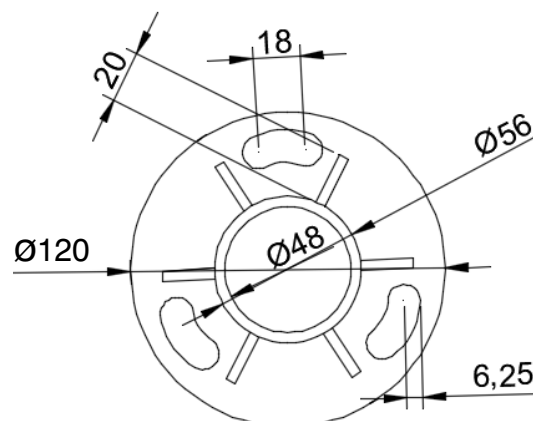
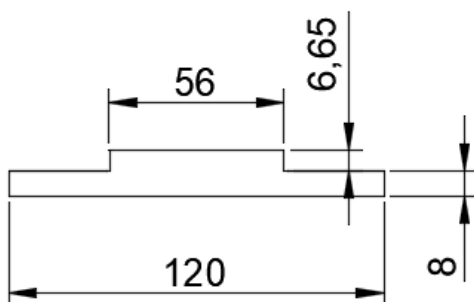

With covers on - 125mm

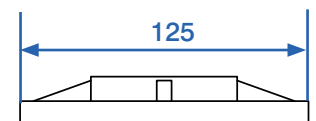



Post parts included

Side fix mounts

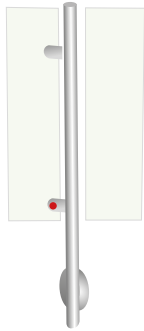

Corner side mount fix

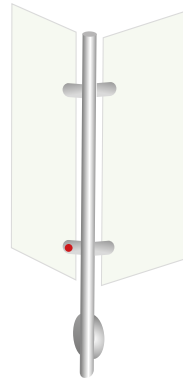

Glass clamp



Mid Post

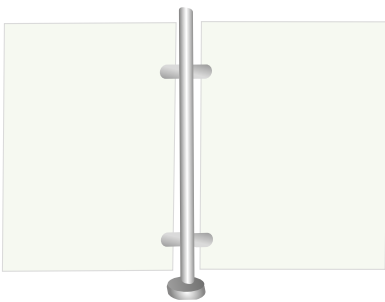

Corner Post

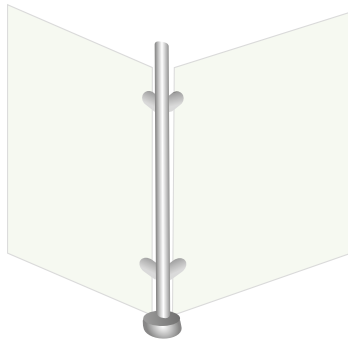

End Post



End Cap



Post Extras

Latch



£50 + VAT ea

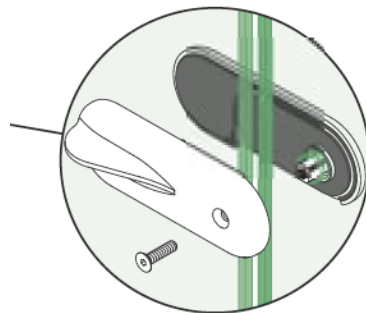

Gate hinged



£90 + VAT per set

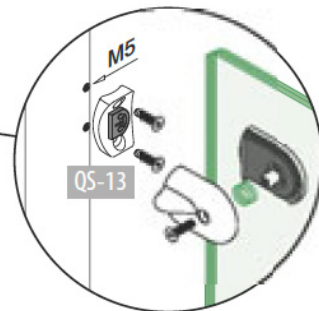
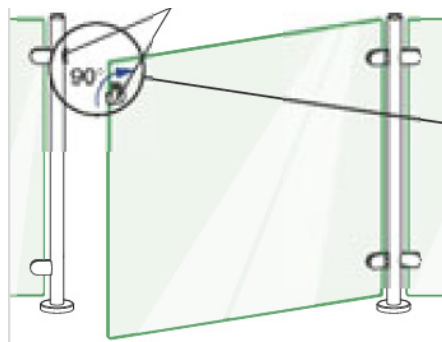

Gate max width is 900mm due to weight of the panels