



Installation Tools

Flex fit tool

Included free of charge with all orders. This is used to align your glass panels. Please see this video link on how to use this – www.made2measure.co.uk/blog/help-and-advice/fitting-glass-in-a-u-channel-balustrade

Combi tool (750mm steel)

This is optional. We only recommend this fitting tool for larger projects or installation companies doing regular works. The tool helps anchoring, removing and installing the glazing blocks and smoothly rolling out the rubber glazing profiles. You can buy this on your order form.

Hammer drill

For concrete you will require a carbide tip masonry drill 12mm W x 180mm L

For other substrates you will need alternative drill bits

Torque wrench and socket set for 10mm bolts

You may need this to tighten your anchors on site.

Dual resin gun

If you purchase our resin you will require a dual resin gun. You can buy this on your order form.

Glass suction cups

This is optional but can help with the movement around site and during the installation itself.

Rubber Mallet

If not using a combi tool you require a rubber mallet and piece of timber to allow you drive the glazing wedges into the channel and ensure they are fixed tightly.

Gloves and wrist guards

This is standard PPE for using and handling glass products safely.

Stanley knife and screwdriver

This is required for trimming any rubber on site if required and if you are attaching a wall flange to a wall.

Loctite 638 glue and Loctite SF7649 activator

Required if fitting slotted handrail. The activator is only used in the event you wish to reduce the drying time for the Loctite 638.

Chop saw with stainless steel cutting blade -

This is only required for a stainless-steel handrail as we always supply lengths slightly longer than required. This allows you to ensure you have an exact fit on site.

During Your Install Process

Stainless steel is quite a soft metal so during your install process refrain from cutting and grinding work close to the components as this can inlay metal sparks/contaminates into your stainless steel which may affect its corrosion resistant qualities. All works should be carried out in an alternate area and cover the any component exposed areas as much as possible if cutting/grinding them.



Essential Features

- Slimline, elegant design and low-maintenance
- Anodized aluminum finish
- FLEXFIT glass adjustment tool to easily align glass panels during installation
- Extension pins and holes to provide a cleaner finish
- Drainage holes and drainage spaces available if required
- Vertical (TL6020) or Horizontal (TL6021) mounting options
- For glass thicknesses between 12 - 21.52 mm
- For applications requiring linear line load of 0.36 - 1.5kN using 12mm - 21.52mm glass
- Increased mounting distances over comparable products in the market reducing installation times
- Profile can be used without an anchor bolt with counter sunk head
- Easy maintenance and glass replacement from the safe side always

TL-6020 Vertical Mount

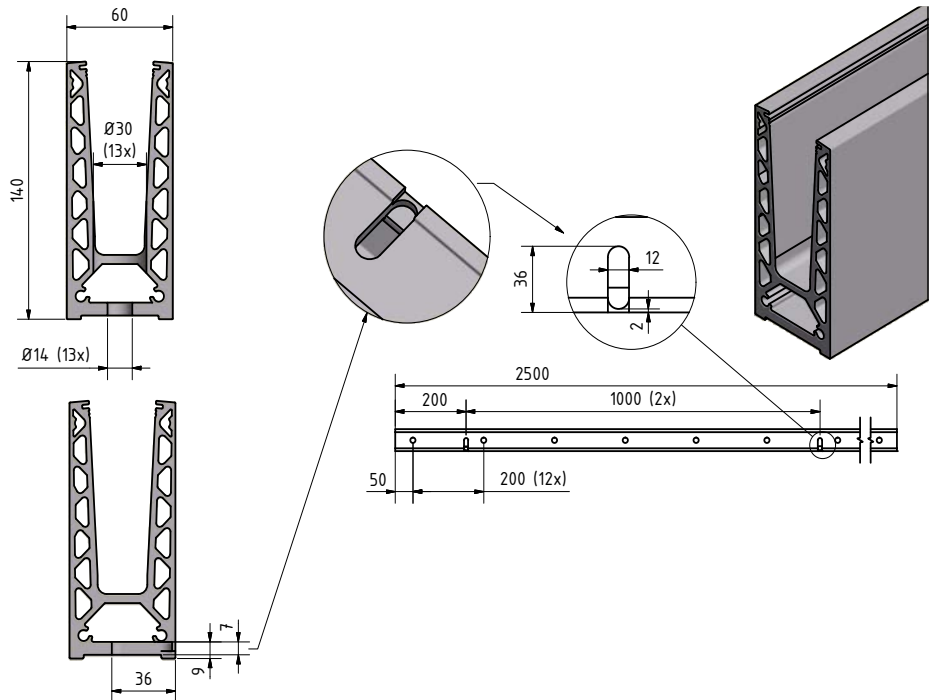

TL-6021 Side Mount

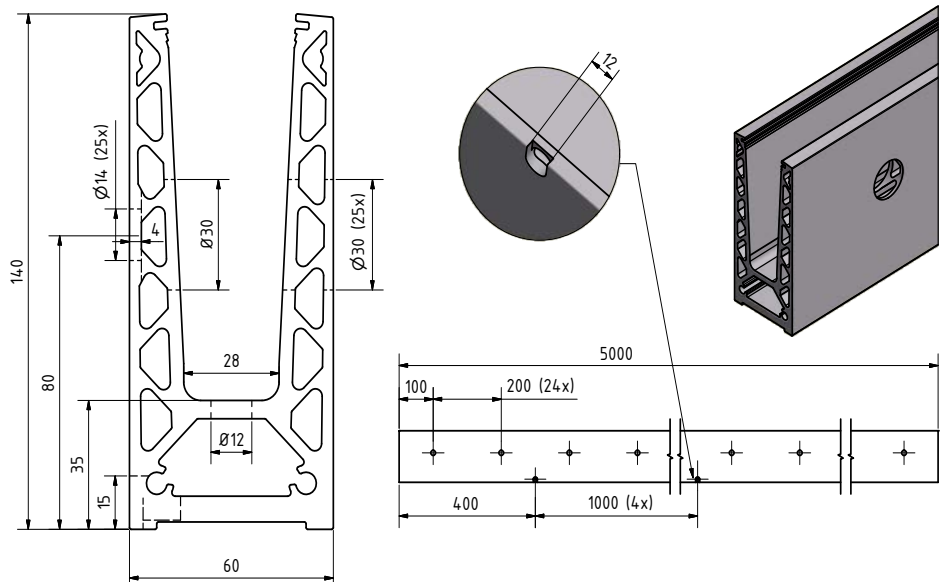



TL Channel Processing options

Example of a join
in the channel



**VERY IMPORTANT
PLEASE READ**

AS STANDARD, ALUMINIUM U CHANNEL IS ROUNDED UP AND QUOTED AND CUT TO THE NEAREST 2.5M

Option 1 – U Channel rounded up and quoted and cut to the nearest 2.5m

All quotes are based on option 1. On all quotes we have rounded up and quoted channel cut to the nearest 2.5m. This gives you added flexibility to cut the handrail to exact length on site. Trade customers will also be able to keep the offcuts for use on future projects if required.

For example, if you required a total of 11 metres - the handrail is charged and supplied as 2 x 5m lengths and 1 x 2.5m length.

If you would like to reduce the number of joins, you can buy additional material at £125 plus VAT per 2.5m length for the TL6020 floor mounted system. For the side mounted TL6021 there is an extra £75 plus VAT for each additional 2.5m of cladding. Please let us know if you would like this added to your order.

Option 2 – U Channel cut to size in the most economical way.

U Channel can be supplied cut to size at £8.50 plus VAT per cut using the channel in the most economical way possible to reduce your material cost. However, this may mean there will be joins in the U channel and extension pins will be included to connect the lengths. The joins will be calculated and shown at the design stage.

For example, on a U run of 4m x 3m x 4m the charge for material is rounded up

to 12.5m. We will be making two cuts to make 2 x 4m channel lengths and supplying x3 pieces of 1m channel for the 3m side charged as one additional cut to make up the 11m.

Please advise us if you would like to choose option 2.

Option 3 – U Channel supplied to the nearest 2.5m for each side for minimum joins

Please advise us if you would like to reduce any unnecessary joins in the channel by buying maximum lengths for each side.

For example, on a 11m U run of 4m x 3m x 4m we can supply a quote for a total of 15m (3 x 5m lengths).

Option 4 – U Channel cut to size for minimum joins.

In addition, we could cut this to size for an additional £8.50 plus VAT per cut.

Example for a 11m U run (4m x 3m x 4m)

Cut out of x2 5m and 1 x 2.5m lengths

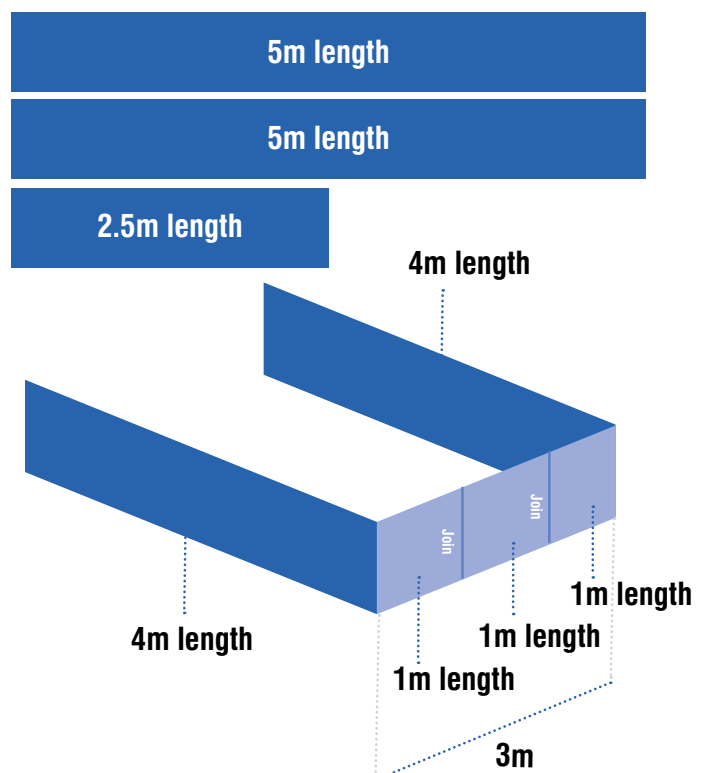



Channel Extras

CHANNEL PARTS INCLUDED

Welded corner

Our welded corners are 200mmx 200mm.

Each corner has a 90D angle and a fixing anchor point positioned in each side of the mitered joint



TL6021 cladding

With mounting strips

For use with a cover cap, end caps must be ordered separately.



Flexi Fit Tool

Supplied free of charge to work in conjunction with the Flex fit systems. Please see page 14

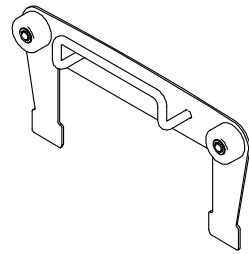

Flexi Fit

Flex Fit system is for fine adjustment of glass panels. This system allows you to adjust the position of each glass panel up to 40 millimeters in relation to the perpendicular. It is the solution for perfect and secure alignment of glass balustrades. With just a simple sliding movement you precision-position the glass, reducing the assembly time by some 30%.

Please visit this link to show how the Flexi Fit alignment works: www.made2measure.co.uk/blog/help-and-advice/fitting-glass-in-a-channel-balustrade



Glass thickness	Wedge colour
12mm	black
13.25mm	gey
15mm	yellow
17.52mm	green
21.52mm	green

CHANNEL PARTS NOT INCLUDED IN SYSTEM PRICE

End caps

For use on left and right

Includes 3M mounting strips

£19.95 + VAT ea

If you have selected end caps in the quote these will have been included.

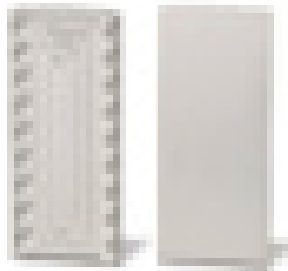

Stair end cap

225mm long with 3M mounting strips

Includes angle markings to help you on site with your cut

£30 + VAT ea



Drainage spacer

You do not have any drainage options on your balcony?

So that you do not need to install a dam on your balcony you can simply mount these spacers beneath your profile where you place each anchor.

Inner hole 14mm

£3.35 + VAT ea

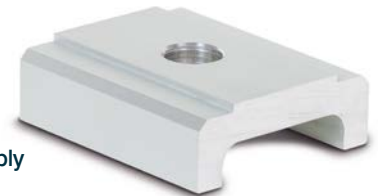

Extension pin

Length: 40 mm

Diameter: Ø 6 mm

These are included if you pay for cut to size channel

£0.80 + VAT ea



Combi Tool

Using this combi tool you can easily drive the pegs in and smoothly roll out the rubber into the profile.

£70 + VAT ea



Stair lock

Simply screw Stair lock into the profile and insert the glass. The glass can now no longer slip downwards. Depending on glass dimensions, the installation effort may be reduced by up to 80%. Less installers, increased safety and a well-conceived system behind

£6.95 + VAT pair





Channel Installation TL6020

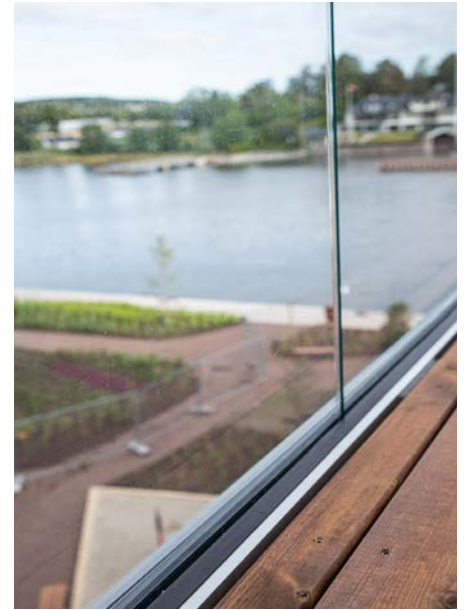
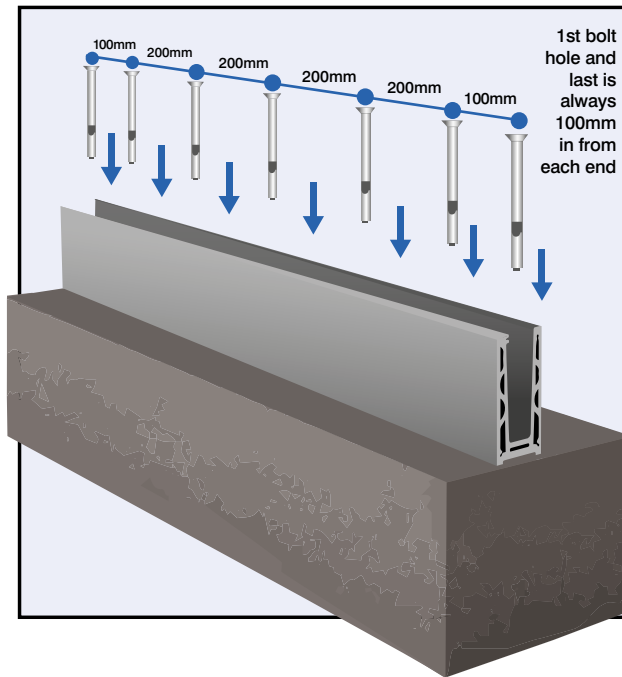
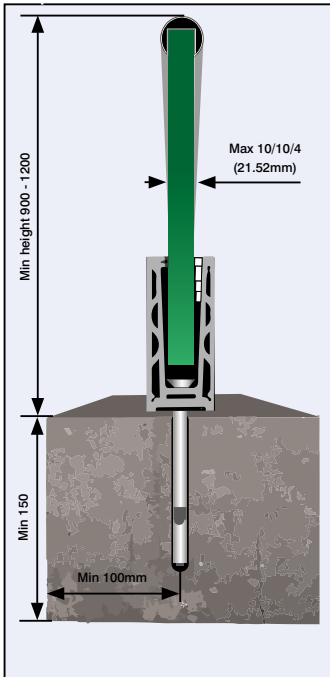

Channel Installation TL6021

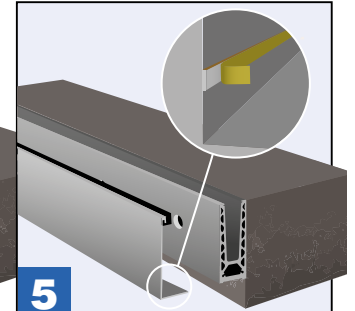
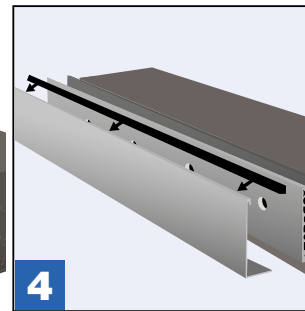
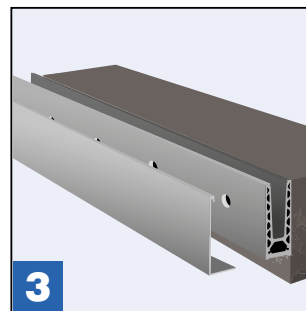
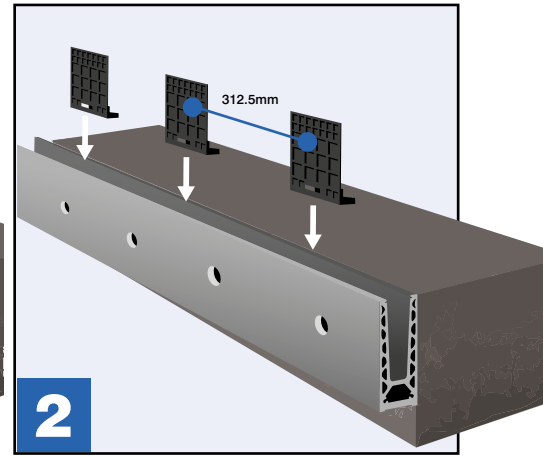
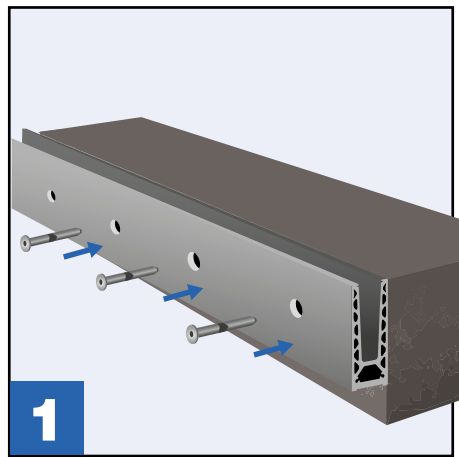
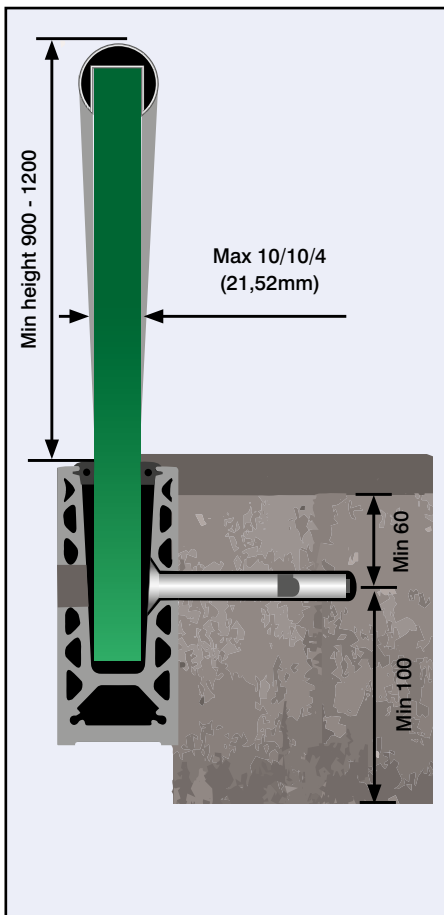



Flex-Kit installation

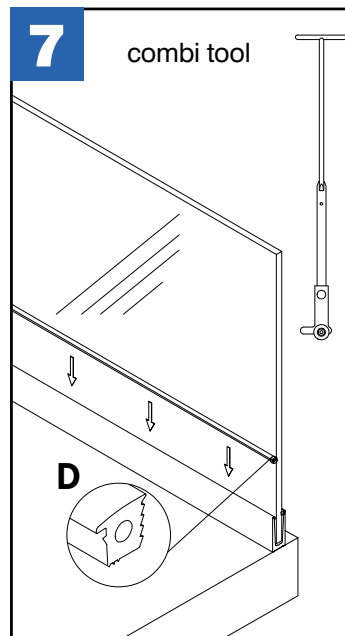
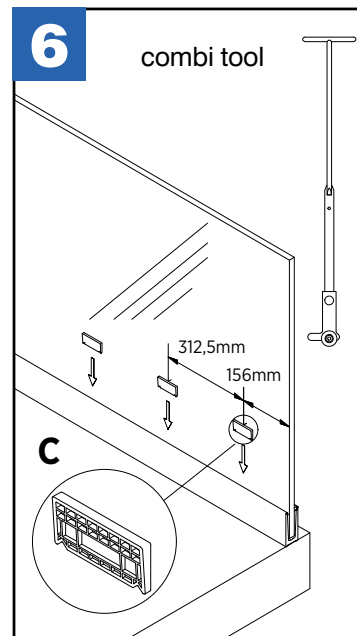
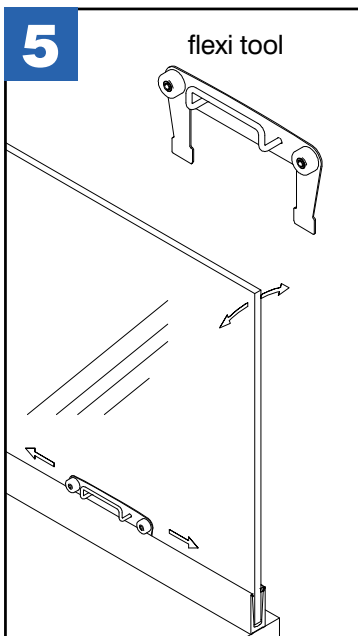
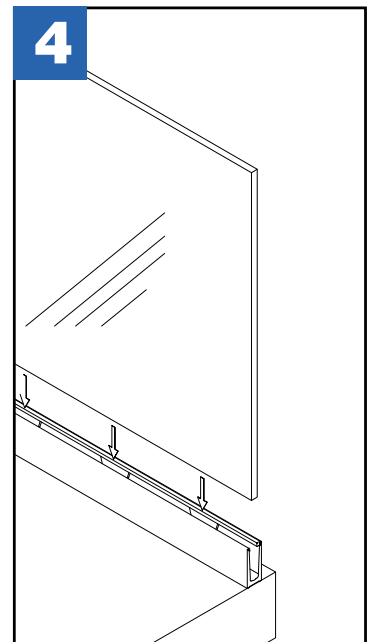
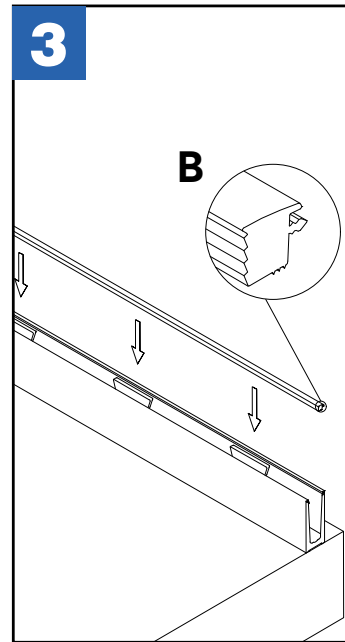
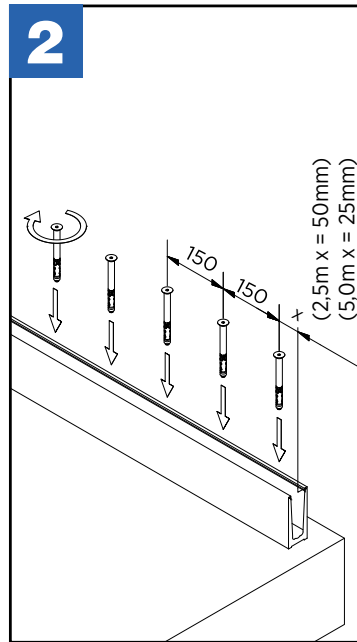
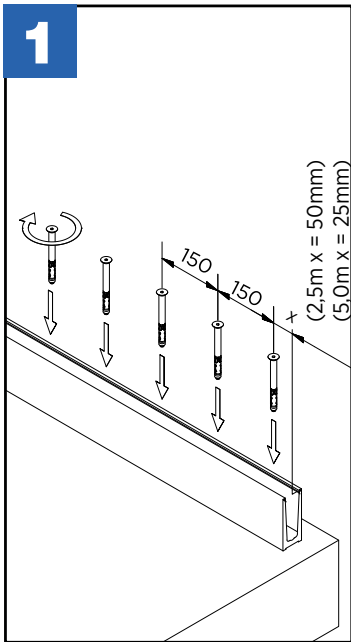
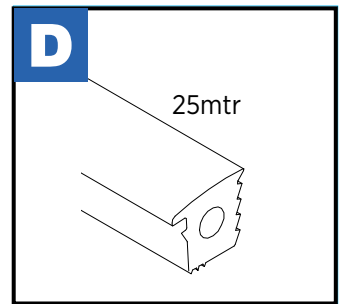
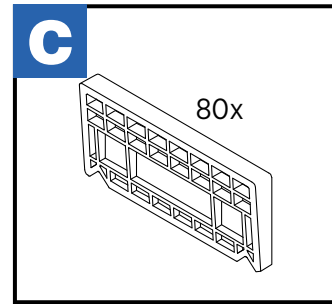
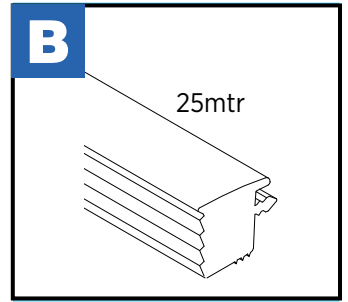
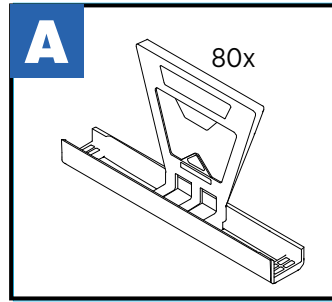

See our short video
www.made2measure.co.uk/blog/help-and-advice/fitting-glass-in-a-channel-balustrade



Model TL4010

Suitable up to H1535mm - Ideal as privacy screen

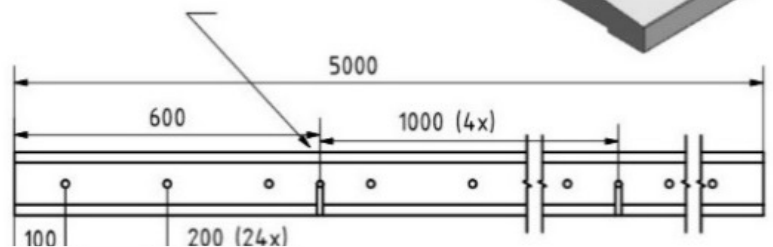
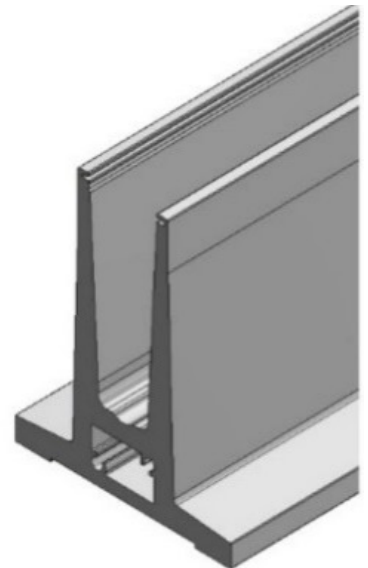
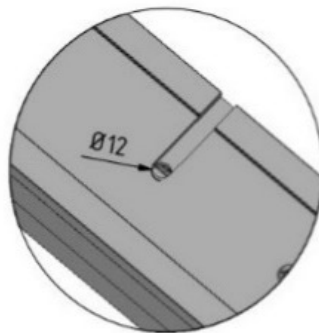
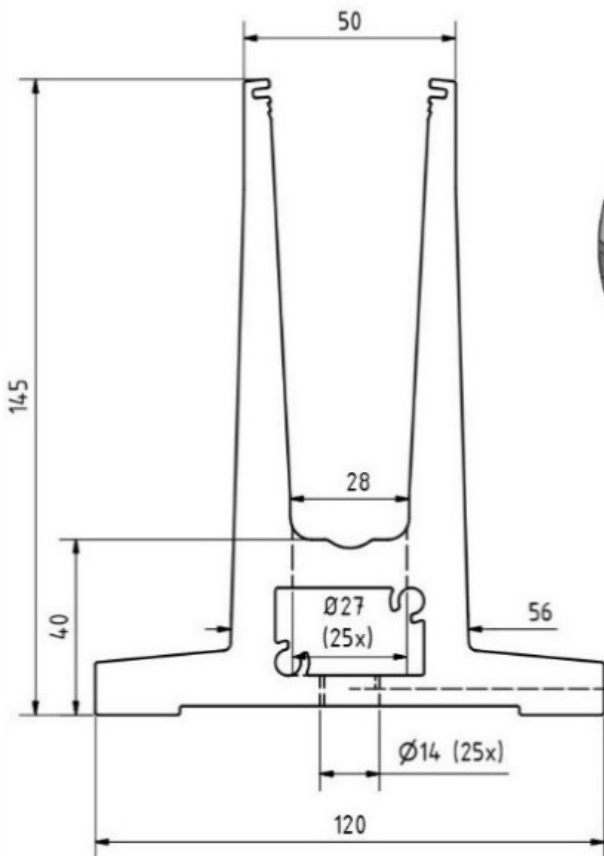

The TL4010 is a model which will require manual intervention to quote. It can be used where additional height is required for example as a privacy screen - the maximum height of the glass panels is 1500mm with a max width of 1150mm. If you require height over 1530mm you would require remedial works to build a small retaining wall or suitable substrate to provide this additional to the a fix the TL4010 safely to. It can be used in conjunction with the 6020 or 6021 but is only available as a vertical mount. If you require pricing please email sales@made2measure.co.uk



Handrail inclusions

Slotted handrail

Grade 316SS brushed external grade 48mm diameter. Cut to size or supplied in 5m or 2.5m lengths. Please see opposite for more details.



EPMD external glazing rubber

Always provided cut to size and available for 12mm / 15mm / 17.52mm / 21.5mm. Simply apply on top of glass once positioned for the handrail to sit safely on top. Does not require adhesive.



Slotted corner handrail connector

This where the handrail meets in a corner and can be either slotted or glued into position.

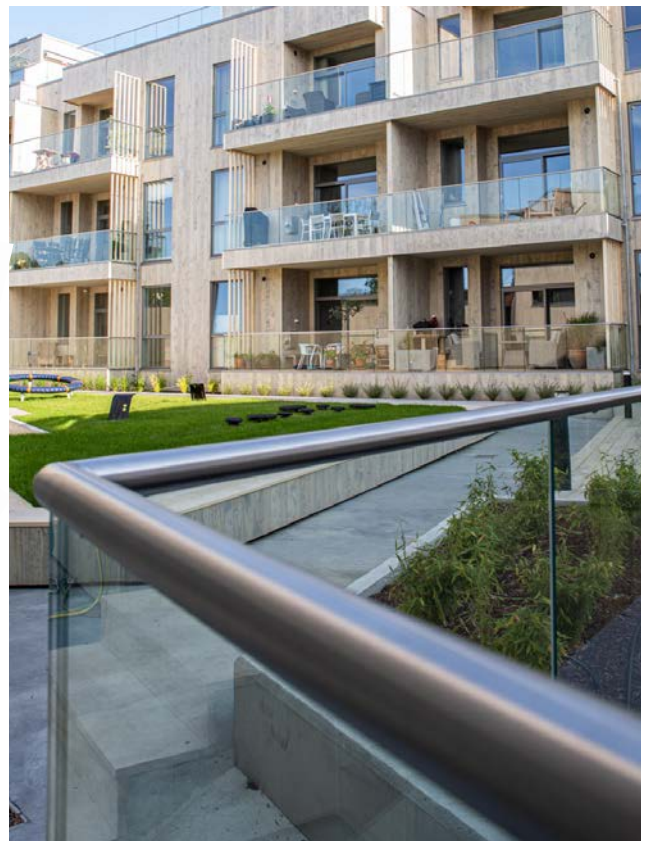

Handrail extras

Glass trim

The top flush-fitting handrail applied to the top of the glass panels. This is cosmetic and can help ground or hiding bends in the glass but this is not handrail solution **Please ask sales for price**



Slotted handrail end cap

A simple and elegant finish for your handrail if it is not being attached to the wall - if you have selected end caps in quote these will have already been added to your total.

Slotted handrail cap £6.50 + VAT ea



Slotted hand rail connector

This is used where there is a handrail that needs to be joined, it is designed with a tight fit so you do not need to use glue - but can do if you so desire. Slotted handrail connectors £7.95 + VAT ea



Slotted handrail wall flange

This wall fixed fitting should always be used where possible as it will significantly improve the performance of your system. If you have selected wall flanges in quote these will have already been added to your total.

Slotted wall flanges £9.95 + VAT ea



Adjustable slotted handrail connector

This useful component can be used where you require horizontal adjustment for your handrail system.

Adjustable slotted handrail connector £18.95 + VAT ea



Why should I use a handrail?

Where your protection from a fall is over 600mm in height. You **MUST** use a handrail if using 12mm or 15mm single glaze toughened glass to stay legally compliant. The glass in such instances is considered infill and the handrail is playing a significant role in the design and strength of your system. We recommend a handrail for anything 8m or higher for additional security and strength. This is a recommendation only but it is worth serious consideration.

Another significant advantage of using a handrail is decreased installation times as aligning the glass does not need to be as precise when using a handrail.

Finally glass panels can have some degree of deflection / bend within them. The industry accepted manufacturing tolerance for deflection / bend is up to a maximum of 3mm over a 900mm size panel. By using a handrail any deflection can be hidden and this can offer a cleaner finish than selecting no handrail.

Certainly if safety is your overriding concern always use a handrail regardless of glass selection, with toughened laminated being the safest glazing option we offer.



Slotted handrail processing options

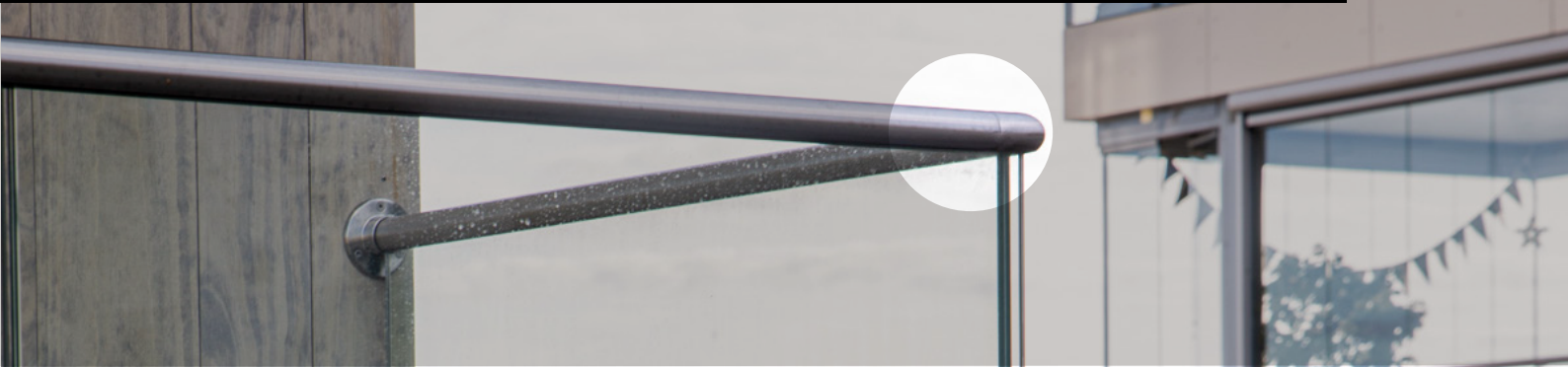

VERY IMPORTANT PLEASE READ AS STANDARD, HANDRAIL IS ROUNDED UP AND QUOTED AND CUT TO THE NEAREST 2.5M

Option 1 – Handrail rounded up and quoted and cut to the nearest 2.5m

You will be quoted for option 1.

On all quotes we have rounded up and quoted handrail cut to the nearest 2.5m. This gives you added flexibility to cut the handrail to exact length on site. Trade customers will also be able to keep the offcuts for use on future projects if required.

For example, on a U run 3m x 4m x 3m you require a total of 11 metres - the handrail is charged and supplied as 2 x 5m lengths and 1 x 2.5m length.

If you would like to reduce the number of joints, you can buy additional material at £50 plus VAT per 2.5m length. Please let us know so we can add this to your order.

Option 2 – Handrail cut to size in the most economical way.

Handrail can be supplied cut to size at £4.00 plus VAT per cut using the handrail in the most **economical way possible** to reduce your material cost. However, this may mean there will be joints in the handrail that will require handrail connectors. These are sold separately and will be added to the order after we have calculated at the design stage how many are required.

For example, on a U run of 4m x 3m x 4m the **charge for material is rounded up to 12.5m**. We will be making two cuts to make 2 x 4m handrail lengths and supplying x3 pieces of 1m handrail for the 3m side charged as one additional cut to make up the 11m.

Please advise us if you would like to choose option 2.

Option 3 – Handrail supplied to nearest 2.5m for each side with minimum joints

Please advise us if you would like to reduce any unnecessary joints in the handrail by buying maximum lengths for each side.

For example, on a 11m U run of 4m x 3m x 4m we can supply a quote for a total of 15m (3 x 5m lengths).

Option 4 – Handrail cut to size for minimum joints

In addition, if requested we can cut this to size for an additional £4 plus VAT per cut.

Example for a 11m U run (4m x 3m x 4m)

Cut out of x2 5m and 1 x 2.5m lengths

